

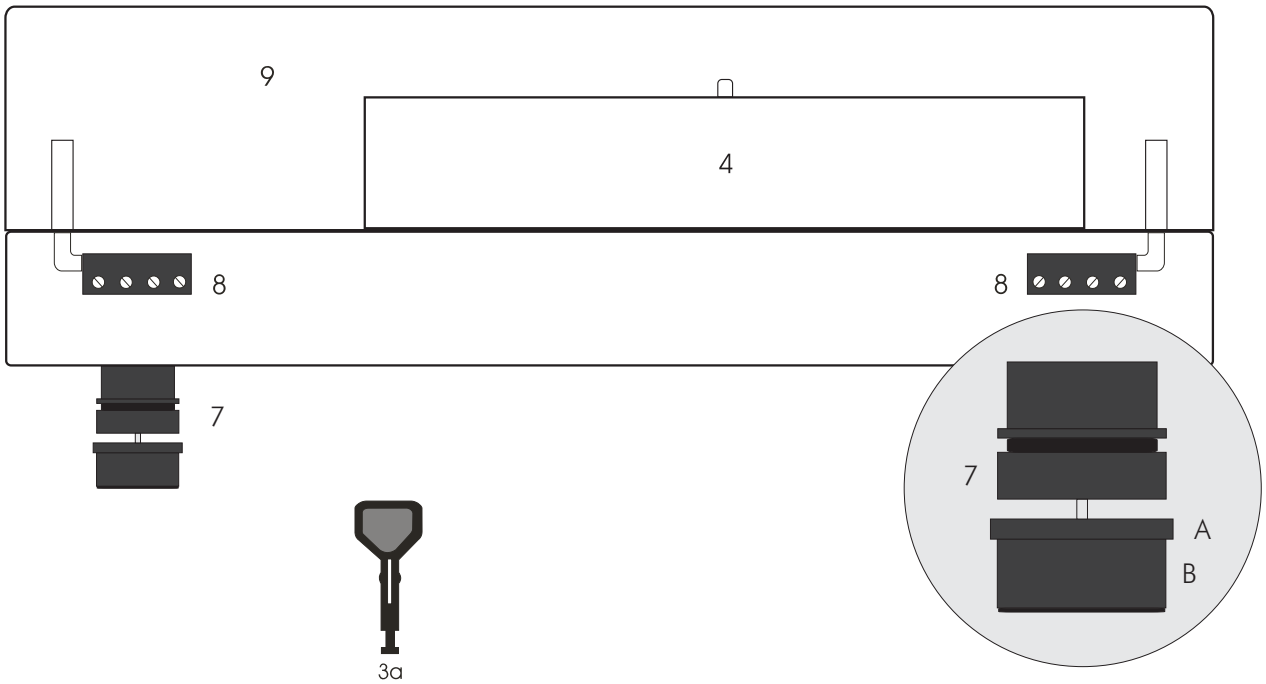

INSTRUCTIONS FOR USE  
Pro-Ject **X**tension 12 Evolution  
Pro-Ject **X**tension Ortofon RS/AS

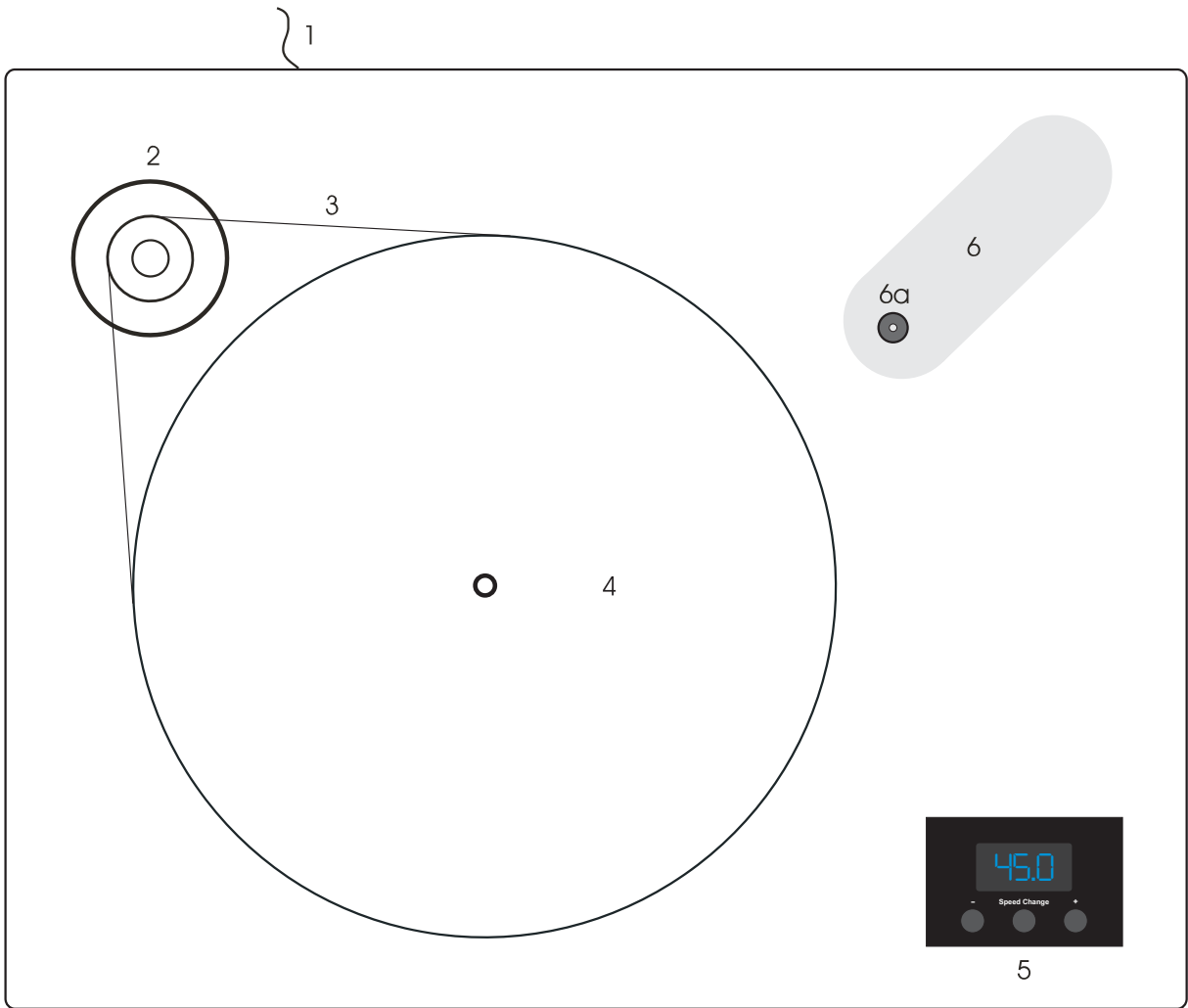



## Set-up

The deck is supplied partially disassembled and carefully packaged for safe transport. Carefully remove all parts from the transport packaging.

Screw the four feet (7) onto the threaded bolts located on the underside of the plinth. Make sure the surface you wish to use the turntable on is level (use a spirit level) before placing the turntable on it.

Carefully place the platter bearing housing over the bearing axle. Put the record weight on the platter and level the plinth using the spirit level (6a) and the adjustable feet (7).

To adjust the feet, hold (A) and turn (B). Turning (B) clockwise decreases the height, turning anticlockwise increases the height of the feet.

Fit the drive belt (3) around the platter (4) and the smaller diameter part of the motor pulley (2).

Avoid getting sweat or grease on the belt as these will deteriorate the performance and reduce the belt's lifespan. Use absorbent kitchen paper to remove any oil or grease from the outer edge of the hub and the belt.

Put the pulley cover on its rests.



*Please note: We recommend to use the record player without a mat on the platter.*

## Fitting the lid

Fit the lid (dust cover 9) carefully over the hinge prongs and adjust the screws (8) until the lid stays open where you want it to without being too stiff to open or close.

## Mains power connection

The turntable is supplied with a power supply suitable for your country's mains supply. Check the label before connecting to ensure compliance with the mains rating in your house.

Connect the low voltage plug from the power supply to the socket (1) on the rear of the record player before connecting the power supply to the mains.

## Starting the motor, Stand By

Pressing the button **Speed Change** will switch on the player from stand by. Press and hold the push button **Speed Change** to put the unit into stand by.

## Changing replay speed

The belt must be on the smaller (50Hz models) larger (60Hz models) diameter part of the motor pulley.

Press the button **Speed Change** to switch between 33 and 45 r.p.m.. The selected speed will be displayed digitally.

To replay records at 78 r.p.m. perform the following steps: Remove the pulley cover. Using the tool (3a), fit the belt (3) around the larger (50Hz models, for 60Hz models the smaller diameter has to be used) diameter step of the pulley (2). Start the turntable by pressing the button **Speed Change** and switch the speed to 45 r.p.m., the platter will then revolve at 78 r.p.m.. The display still shows 45 r.p.m..



## Pitch control

Repeatedly pressing the + or - buttons increases or decreases the replay speed in twenty steps of 0,1 r.p.m. respectively. The adjusted speed is displayed digitally.

## Technical specifications Pro-Ject Xtension 12 Evolution / Ortofon RS-309D/AS-309S

* Electronic speed change	* 33/* 45 and 78 r.p.m.
Speed variance	±0,09 %
Wow and flutter	±0,01 %
Signal to noise	73dB
Power consumption	2W
Outboard power supply	16V/1.000mA AC, suitable for your country's mains supply
Dimensions (W x H x D)	550 x 250 x 450mm, dust cover open 550 x 550 x 560mm
Weight	20kg

### Pro-Ject Evolution tonearms

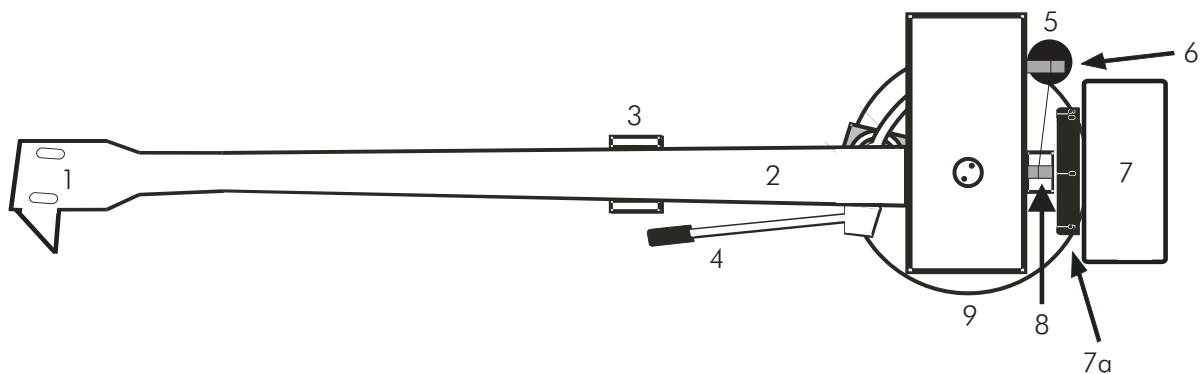

- 1 Headshell with finger lift
- 2 Tonearm tube
- 3 Tonearm rest and removable transport lock
- 4 Tonearm lift lever
- 5 Anti-skating weight \*
- 6 Anti-skating weight wire support
- 7 Tonearm counterweight \* 7a Downforce scale
- 8 Anti-skating weight adjustment scale
- 9 Tonearm base

### Cartridge downforce adjustment (Pro-Ject Evolution tonearms)

Remove the transport lock (3) from the tonearm. Store it in the original packaging so they are available for any future transportation.

Pushing carefully, turn the counterweight (7) onto the rear end of the tonearm tube (2), and so that the downforce scale (7a) shows towards the front of the player. Lower the armlift and position the cartridge in the space between arm rest and platter. Carefully rotate the counterweight (7) until the armtube balances out. The arm should return to the balanced position if it is moved up or down. Do not forget to remove the cartridge protection cap if fitted.

Once the arm is correctly balanced return it to the rest (3). Hold the counterweight (7) without moving it, and gently revolve the downforce scale ring (7a) until the zero is in line with the anti-skating prong (8). Check whether the arm still balances out.

Rotate the counterweight counter clockwise (seen from the front) to adjust the downforce according to the cartridge manufacturer's recommendations. One mark on the scale represents 1 mN (= 0,1g / 0,1 Pond) of downforce.

**Tonearm Pro-Ject 12cc Evolution:** The counterweights (7) supplied are suitable for cartridges weighing between 4 - 7g (counterweight no. **27**), 6 - 9g (counterweight no. **31**), 8 - 12g (counterweight no. **32**) or 10 - 14g (counterweight no. **33**).



Please note: Adjust the downforce prior to installing the anti-skating weight.

## Adjusting the azimuth (Pro-Ject Evolution tonearms)

The cartridge needle must be vertical in the record groove in order to trace the groove wall modulations correctly.

A small screw at the bearing end of the arm allows incorrect azimuth to be corrected if your needle is not mounted exactly perpendicular to the cartridge body (which is often the case).

Slacken off the screw just enough to be able to revolve the arm tube without applying force. Note! Do not remove the screw completely!

With the aid of a good magnifying glass adjust the needle until it is vertical in the groove (i.e. perpendicular to the record's surface). Ideally this should correspond to the top surface of the cartridge body being parallel to the record surface, but in practice this is often not the case.

When you are satisfied that the needle is vertical retighten the screw carefully.



*Please note: Under no circumstances should the arm tube be adjusted with the needle still in the record groove! Irreparable damage may be caused to the cantilever suspension! The arm must be lifted to make each adjustment and lowered afterwards to check it.*

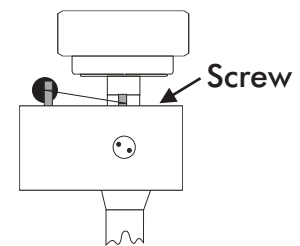

## Anti-skating force adjustment (Pro-Ject Evolution tonearms)

The anti-skating force must be adjusted corresponding to the downforce as follows:

<u>Downforce</u>	<u>Groove in the stub (8)</u>
10 - 14mN	1 <sup>st</sup> from bearing rings
15 - 19mN	2 <sup>nd</sup> " " "
20mN and bigger	3 <sup>rd</sup> " " "

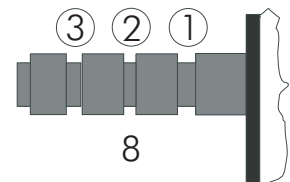

Hang the loop of the thread of the anti-skating weight (5) in the groove of the anti-skating stub (8) corresponding to the downforce applied to your cartridge and hang the thread in the groove of the wire support (6).

## Adjusting the vertical tracking angle -vta- (Pro-Ject Evolution tonearms)

Put a record on the platter. When the needle is lowered into the record groove and the tonearm is not resting on the tonearm rest (3), the tube (2) of the tonearm should be parallel to the surface of the record.

If it is not loosen both hexagon screws in the tonearm base (9) just enough to allow vertical movement of the arm pillar without force and slide the arm up or down until it is parallel.

Carefully retighten the hexagon screws without applying excessive force (which would deform the arm pillar) – finger tight is quite sufficient.

## Ortofon RS tonearms

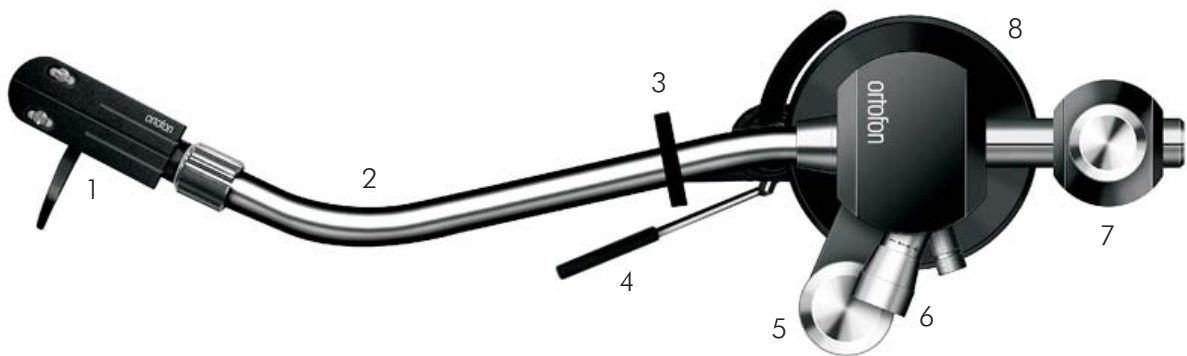

- 1 Detachable headshell with finger lift
- 2 Tonearm tube
- 3 Tonearm rest and removable transport lock
- 4 Tonearm lift lever
- 5 Anti-skating force adjustment knob
- 6 Downforce adjustment knob
- 7 Tonearm counterweight with securing screw\*
- 8 Tonearm base  
Stylus pressure gauge (not shown) \*

### Cartridge downforce adjustment (Ortofon RS tonearms)

Remove the transport lock (3) from the tonearm. Store it in the original packaging so they are available for any future transportation. Set the knob (5) to 0.

Place the counterweight (7) halfway along the counterweight support rod at rear of arm, being sure to have the counterweights (7) securing screw uppermost. Lower the armlift and position the cartridge in the space between tonearm rest (3) and platter. Carefully move the counterweight (7) along the support rod, until the armtube (2) balances out. The arm should return to the balanced position if it is moved up or down. Do not forget to remove the cartridge protection cap if fitted.

With the power off, and the platter static, place the supplied stylus pressure gauge onto the platter.

Carefully lower the armlift and position the tip of the stylus on the pressure gauges measuring tongue. The downforce will be displayed digitally.

Adjust the Downforce, using the knob (6), to the cartridge manufacturer's recommendations. This adjustment must be done with the tonearm resting on the tonearm rest (3). Finally secure the counterweight with the securing screw (7).

The counterweight (7) supplied is suitable for cartridges weighing between 18 - 40g.



*Please note: Adjust the downforce prior to setting the anti-skating compensation.*

### Anti-skating force adjustment (Ortofon RS and AS tonearms)

The anti-skating force must be adjusted corresponding to the downforce. Rotate the knob (5) to adjust the Anti-skating force. One mark on the scale represents 5 mN (= 0,5g / 0,5 Pond) of downforce.

### Adjusting the vertical tracking angle -vta- (Ortofon RS and AS tonearms)

Put a record on the platter. When the needle is lowered into the record groove and the tonearm is not resting on the tonearm rest (3), the surface of the cartridge body should be parallel to the surface of the record.

If it is not loosen the hexagon screw in the tonearm base (8 RS tonearms or 7 AS tonearms) just enough to allow vertical movement of the arm pillar without force and slide the arm up or down until it is parallel.

Carefully retighten the hexagon screw without applying excessive force (which would deform the arm pillar) – finger tight is quite sufficient.

## Ortofon AS tonearms

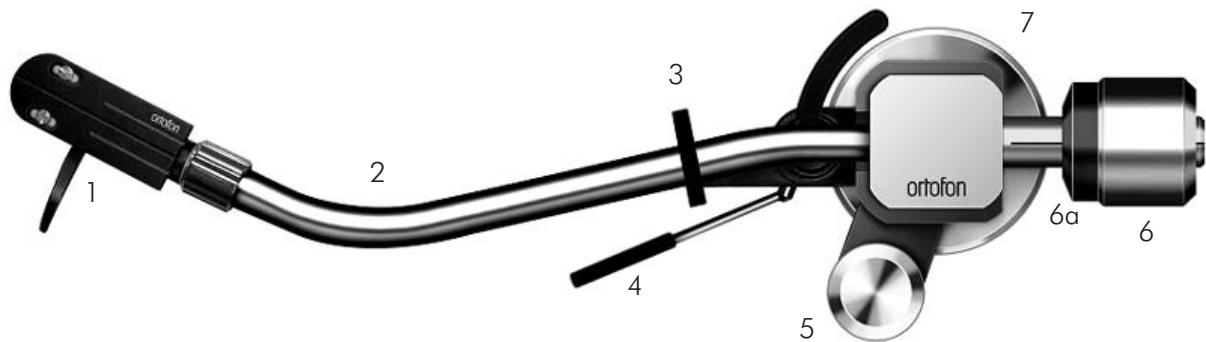

- 1 Detachable headshell with finger lift
- 2 Tonearm tube
- 3 Tonearm rest and removable transport lock
- 4 Tonearm lift lever
- 5 Anti-skating force adjustment knob
- 6 Tonearm counterweight \*      6a      Downforce scale
- 7 Tonearm base

### Cartridge downforce adjustment (Ortofon AS tonearms)

Remove the transport lock (3) from the tonearm. Store it in the original packaging so they are available for any future transportation. Set the knob (5) to 0.

Pushing carefully, turn the counterweight (6) onto the rear end of the tonearm tube (2), so that the downforce scale (6a) shows towards the front of the player. Lower the armlift and position the cartridge in the space between arm rest and platter. Carefully rotate the counterweight (6) until the armtube balances out. The arm should return to the balanced position if it is moved up or down. Do not forget to remove the cartridge protection cap if fitted.

Once the arm is correctly balanced return it to the rest (3). Hold the counterweight (6) without moving it, and gently revolve the downforce scale ring (6a) until the zero is in line with the black line at the rear end of the tonearm tube (2). Check whether the arm still balances out.

Rotate the counterweight counter clockwise (seen from the front) to adjust the downforce according to the cartridge manufacturer's recommendations.

The counterweight (6) supplied is suitable for cartridges weighing between 18 - 25g. An alternative weight for cartridges weighing between 26 - 38g is available as an accessory part.



*Please note: Adjust the downforce prior to setting the anti-skating compensation.*

### Anti-skating force adjustment and Adjusting the vertical tracking angle -vta-

See Ortofon RS tonearms

### Connection to the amplifier

Connect the tonearm cables to the Phono input (sometimes labelled gram, disc or RIAA) on your amplifier. Make sure that the phono input offers correct matching and amplification for the type of cartridge used. Line inputs (such as CD, Tuner, Tape or Video) are not suitable.

Take care to connect the left and right channels correctly. The right channel is usually marked red, the left channel black or white. Check the manual supplied with your amplifier for relevant information. An earthing wire may be connected to the screw terminal on your amplifier if you encounter hum problems when using the record player.

If your amplifier does not have an input suitable for phono cartridges you will require a separate phono amplifier stage for MM or MC cartridges which is then connected between the record player and a free line level input of the amplifier.

For detailed product information regarding Pro-Ject Audio phono amplifiers please refer to the Pro-Ject web site [www.project-audio.com](http://www.project-audio.com).



## Fitting and connecting the cartridge

All cartridges with half inch mounting holes can be fitted. Leaving the needle's protection cover on, fit the cartridge to the headshell using the screws supplied with the cartridge by passing one screw through each slot in the headshell (1). Do not tighten the nuts yet.

Connect the tonearm wires to the cartridge pins as follows:

white	left channel positive (L+)
red	right channel pos. (R+)
green	right channel return (R -)
blue	left channel return (L -)

The full sound quality of the record player can only be achieved if the cartridge is correctly adjusted. Particular tools like the Pro-Ject alignment tool are required to accomplish this job properly.

If you are not well acquainted with the adjustment of cartridges you are advised to call upon the willing help of your Pro-Ject dealer to accomplish this task for you.



*Please note: Adjusting a cartridge and tonearm calls for the greatest care in order to avoid damaging the cartridge or tonearm bearings. Leave this work to your dealer if you are in any way unsure of the necessary steps and precautions to be taken.*

## Technical specifications Pro-Ject 12cc Evolution

Tonearm	medium mass
Supplied counterweights	cartridge weight 4 - 7g, 6 - 9g, 8 - 12g or 10 - 14g
Downforce range	10 - 35mN
Effective tonearm mass	10,5g
Effective tonearm length	12 " (304,8mm)
Overhang	13,2mm
Weight	271g (without counterweight)
Lenght Connect it connection cable	123cm
Capacity tonearm cable	65pF/meter

## Technical specifications Ortofon RS-309D

Tonearm	medium mass
Supplied counterweight	cartridge weight 18 - 40g (including headshell)
Downforce range	0 - 50mN
Effective tonearm mass	6g
Effective tonearm length	326mm
Overhang	15mm
Offset angle	19 degrees
Weight	725g (plus headshell and cartridge)
Lenght Connect it connection cable	123cm
Capacity tonearm cable	65pF/meter

## Technical specifications Ortofon AS-309S

Tonearm	medium mass
Supplied counterweight	cartridge weight 18 - 25g (including headshell)
Optional counterweights	cartridge weight 26 - 38g (including headshell) weight D
Downforce range	0 - 50mN
Effective tonearm mass	5g
Effective tonearm length	326mm
Overhang	15mm
Offset angle	19 degrees
Weight	535g (plus headshell and cartridge)
Lenght Connect it connection cable	123cm
Capacity tonearm cable	65pF/meter

## Potential incorrect use and fault conditions

Pro-Ject turntables are manufactured to the highest standards and undergo strict quality controls before leaving the factory. Faults that may possibly occur are not necessarily due to material or production faults but can sometimes be caused by incorrect use or unfortunate circumstances. Therefore the following list of common fault symptoms is included.

### The platter doesn't turn although the unit is switched on:

- The unit is not connected to the mains power supply.
- No mains at the socket.
- Drive belt is not fitted or has slipped off.

### No signal through one or other channel or both channels:

- No signal contact from the cartridge to the internal tonearm wiring or from that to the arm lead or from that to the phono box or between that and the amplifier. This could be due to a faulty plug, broken wire or solder joint or simply loose plug/socket connection.
- Phono input not selected at amplifier.
- Amplifier not switched on.
- Amplifier or speakers defective or muted.
- No connection to the loudspeakers.

### Strong hum on phono input:

- No earth connection from cartridge or arm or arm cable to amplifier, or earth loop.

### Distorted or inconsistent sound from one or both channels:

- Record player is connected to wrong input of amplifier, or MM/MC switch incorrectly set.
- Needle or cantilever damaged.

Wrong r.p.m., drive belt overstretched or dirty, platter bearing without oil, dirty or damaged.

## Maintenance and cleaning

Your record player requires little or no regular maintenance. Remove dust with the supplied antistatic cloth. It is recommended to fit the needle cover before cleaning or maintenance is carried out to avoid damage. If the player is not used over a long period of time the drive belt can be removed to prevent unequal stretching.



*Always disconnect the record player from the mains power supply as a precaution before maintenance!*

## Service

Should you encounter a problem which you are not able to alleviate or identify despite the above information, please contact your dealer for further advice. Only when the problem cannot be resolved there should the unit be sent to the responsible distributor in your country.

Guarantee repairs will only be effected if the unit is returned correctly packaged. For this reason we recommend keeping the original packaging.

Never return a record player without making sure that it is safely disassembled and correctly packaged in the original packaging according to the supplied diagram. Please remove these parts and pack them separately: feet, counterweight, platter, cartridge and belt. Fit the cartridge protection cap. Insert the transport lock for the tonearm prior to carefully packaging the record player.

## Warranty



*The manufacturer accepts no responsibility for damage caused by not adhering to these instructions for use and/or by transportation without the original packaging. Modification or change to any part of the product by unauthorized persons release the manufacturer from any liability over and above the lawful rights of the customer.*

## Copyright

PRO-JECT is a Registered Trademark of H. Lichtenegger. The information was correct at the time of going to press. The manufacturer reserves the right to make changes to the technical specification without prior notice as deemed necessary to uphold the ongoing process of technical development.